

DESIGNING PLASTIC CUPES RING CUTTING MACHINE TO INCREASE PRODUCTIVITY

1,2) Department of Mechanical Engineering, Bali State Polytechnic.
Bukit Jimbaran P.O. Box 1064 Tuban, Badung – Bali
Phone : (0361) 701981, Fax. (0361) 701128

Corresponding email ¹⁾ :
wibolo@pnb.ac.id

Achmad Wibolo ¹⁾, I Nengah Ludra Antara ²⁾

Abstract. *The existence of plastic makes the society's lives easier and more practical. Recently, the various kinds of products are made from this material because the votes are more durable. Plastics also give a negative effect for the environment such as soil pollution. The purpose of designing this plastic cup ring cutting machine is to sort the kind of plastics and to accelerate the process of plastic recycling, so that the plastic processing can be done faster. The authors designed a plastic cup ring mowers with electric motor mover. The design concepts of this machine are the height of machine is: 90 mm of height with a width of 50 mm, frame in size of 50 mm x 50 mm made from angled steel. This machine uses two vertical cutting blades and one horizontal cutting blade. The activator which is used in this machine is an electric diesel 1/4 HP with the rotation speed of 1400 rpm, belt-V type A38 as a link of the diesel rotation to the spindle. It is used two pieces of cushions because the direction of the load presses is perpendicular to axis of the shaft. So it is used bearing type of UCF pillow block in the diameter of 75 mm. The cutting process is done in a standing position and the button is pressed manually by using manpower, so that the rotation can become stable. If using a machine the process of cutting a ring of plastic cup can be accelerated. Manually it can be produced approximately 5 pieces of plastic cups. But, if using a machine, it can be produced approximately 14 pieces of plastic cups.*

Keywords : Machine, Cutter, Glass Ring, Plastic

1. INTRODUCTION

In everyday life, society is never separated from the use of plastics, which makes people's lives easier and more practical. The use of plastic has expanded almost to all aspects of people's lives. Various products and equipment are produced from this material, because it is considered more durable, not easily broken, flexible, and lightweight. While on the other hand, the plastic also has a negative impact on the environment. Various ways have been taken to reduce the impact of the use of plastic-based products, one of them by accumulating plastic waste, but this way will cause problems in the form of soil contamination because plastic waste is very difficult to decipher by bacteria decomposers naturally.

To reduce the amount of plastic waste, especially plastic cup waste, cutting and separation processes are required on the clear plastic cup section with colored plastic cup parts. In the Tabanan area there are many plastic cup collectors, cutting the plastic cup ring is still using the manual way that affects the safety of its workers. Cutting of plastic cup rings is mostly done by using scissors or cutter. The use of tools in the form of scissors or cutter lies in the way of cutting plastic cup rings. If using a pair of scissors, the plastic cup ring is cut from the top of the glass, then circle the cut glass beam, so that the glass ring is cut off. Meanwhile if it is used a cutter, cutting the plastic cup ring starts on the side of the glass. In the process of cutting the plastic cup rings in a manual way, it is encountered many obstacles, such as: it takes a lot of time to cut a plastic cup and the results were not maximal due to fatigue from humans.

Based on these conditions, the author wishes to facilitate and speed up the process of cutting plastic cup rings. Therefore, the author designed a plastic cup cutting machine with electric motor drive. This plastic cup cutting machine has many advantages: in the process of cutting the plastic cup rings, it can produce a flat piece on

the side of the glass as it is cut vertically and horizontally or circularly according to the diameter of the glass rings. The flat cuts can add weight from plastic cups. The maintenance of this machine is very simple so that the process of replacing components and workmanship can be done independently. [1]

2. METHOD

The previous cutting process has a disadvantage that the cutting process takes quite a long time, and the cut is irregular, so it affects the weight of the plastic cup. The manual cutting process is as shown in Picture 1.



Picture 1: Manual cutting

Based on a survey conducted by the community and collectors about plastic cup waste processing, in order to make the process of cutting glass rings faster and to minimize work accidents, then it can be designed a tool that can increase the economic value of plastic cup waste. The design of plastic cup cutter is as shown in figure 2. [2]

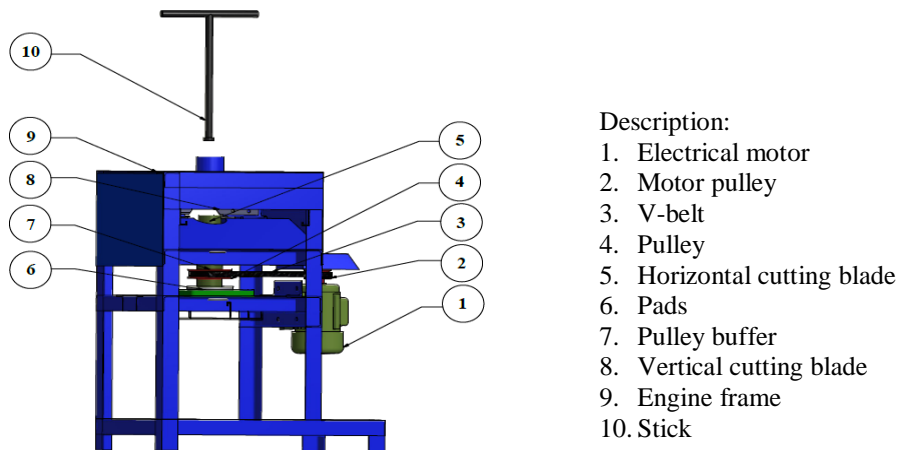

- Description:
1. Electrical motor
 2. Motor pulley
 3. V-belt
 4. Pulley
 5. Horizontal cutting blade
 6. Pads
 7. Pulley buffer
 8. Vertical cutting blade
 9. Engine frame
 10. Stick

Picture 2: the Design of Plastic cup Ring Cutting Machine

The stack of glass rings will be cut in a sustainable or continuous manner using human power (stick presses). In order to cut the glass rings faster, it is made 2 pieces of cutting blades: vertical and horizontal cutting blades. The vertical cutting blade serves to split the glass rings, to allow for faster installation of 2 vertical blades. The split glass rings are meant to separate the rings with a pile of cups. Then after the split, the ring of glass will be cut by a horizontal blade in a circle. The clipped glass result will fall down, so that the results and the glass pieces will be separated. The formula required to calculate the main components of the Plastic Ring Cutting Machine is as follows: [3]

1. Selection of Electrical Motor

$$P = T \cdot \omega = \frac{\pi \cdot n \cdot T}{30} \dots\dots\dots (1)$$

In which:

- T = Torque (N.m).
- F = Total force (N).
- r = Radius (m).
- P = Electrical motor power (Watt).
- n = Rotation on electrical motor shaft (rpm).
- ω = Radian velocity (rad/s).

2. Power Successor with V-Belt

$$L=2C + \frac{\pi}{2} (dp+Dp)+ \frac{1}{4C} (Dp-dp)^2..... (2)$$

In which:

L = length of belt (mm).

C = Distance between axis (mm).

Dp=Diameter of the pulley driven (mm).

dp= Diameter of the mover pulley (mm).

$$N = \frac{P_d}{P_o \cdot K_\theta}..... (3)$$

In which:

N = The amount of the belts needed.

P_d=Power of the motor plan(Hp).

P_o=Capacity of the power transmitted for one belt

K_θ=Correction factor.

3. Planning of the shaft dimension

$$ds = [(5,1/\tau\alpha)\sqrt{(Km.M)^2 + (Kt.T)^2}]^{\frac{1}{3}}..... (4)$$

$$\sigma_b = \frac{M_b}{W_b}.....(5)$$

In which:

ds = Diameter of the shaft (mm).

τ_α = Shear stress (N/mm²).

K_m= For loads with light stacks

K_t= Correction factor

M_b= Bending moment

W_b = Moment of bending resistance.

σ_b = Bending stress.

The research method used is true experimental research. Furthermore, the test is done to get the tuna grinding process which requires the shortest time compared to the results of the survey done.

The test phase of the design is as follows:

- a. Preparing the tools that have been made and other properties.
- b. Observing the operation of the tool, whether to operate according to its function or not
- c. Preparing plastic cupes to be cut (figure 3)
- d. Starting to do the cutting process and record the time by using stopwatch.



Picture 3. a pile of plastic cupes

3. RESULT AND DISCUSSION

3.1 Result

Plastic cup ring cutting machine is a combination of several components required in accordance with its function to support a mechanism, so that it can become a system functioned in accordance with the expectation. The process of making the components of the machine is preceded by the calculation process. The calculation process is:

- a. The electric motors required.

To determine the cutting force (F) the tensile strength of plastic until the plastic is cut off. Tensile strength (σ) of polypropylene type plastic is $40 \text{ N} / \text{mm}^2$. [4]

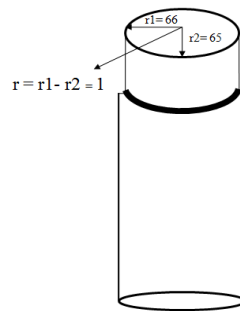

Picture 4. Cutting blade.

$$\begin{aligned}
 F &= \sigma \cdot A \\
 &= 40 \text{ N/mm}^2 \cdot \pi \cdot r^2 \text{ mm} \\
 &= 40 \text{ N/mm}^2 \times 3,14 \times 1^2 \text{ mm} \\
 &= 125,6 \text{ N} \times 1 \\
 &= 125,6 \text{ N}
 \end{aligned}$$

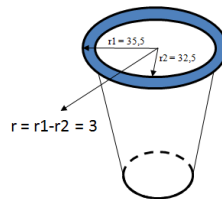

Picture 5. Plastic cup

$$\begin{aligned}
 T &= F \cdot r \\
 &= 125,6 \text{ N} \times 0,003 \text{ m} \\
 &= 0,376 \text{ N.m}
 \end{aligned}$$

To determine the speed at the shaft, it is conducted experiments using the lathe to cut glass rings, the results obtained is assumed to be 950 Rpm. Then the calculation of electric motor power as follows:

$$\begin{aligned}
 P &= \frac{\pi \cdot n \cdot T}{30} \\
 &= \frac{3,14 \times 950 \text{ rpm} \times 0,376 \text{ N.m}}{30} \\
 &= \frac{2.983 \times 0,376}{30} \\
 &= 0,050 \text{ Hp}
 \end{aligned}$$

To obtain a safe plan power, the nominal power must be multiplied by the correction factor (fc) 1.5, then:

$$\begin{aligned}
 P_d &= P \cdot f_c \\
 &= 0,050 \text{ Hp} \times 1,5 \\
 &= 0,075 \text{ Hp}
 \end{aligned}$$

So the electric motor power used is 0.075 kW ~ 0.25 Hp. The specific data of the electric motor is as follows:

- Type : AC electric motor
- Motor power : 0.25 Hp
- Type : JY09A- 4
- Frequency : 50 Hz
- Rotation : 1400 rpm

b. The V-belt used

1) Determining the diameter of the drive pulley (dp)

Drive rotation (n_1) = 1400 rpm
 Driven rotation (n_2) = 950 rpm
 Diameter of the drive pulley (D_p) = 127 mm
 $n_1/n_2 = D_p/d_p$
 $1400/950 = 127/d_p$
 $1400d_p = 950 \cdot 127$
 $d_p = 76,2 \text{ mm}$

2) Length of the V-belt (L)

$C = 2 \cdot D_p$
 $= 2 \cdot 127$
 $= 254 \text{ mm}$
 $L = 2C + \frac{\pi}{2} (d_p + D_p) + \frac{1}{4C} (D_p - d_p)^2$
 $L = 2 \times 254 + \frac{3,14}{2} (76,2 + 127) + \frac{1}{4 \times 254} (127 - 76,2)^2$
 $= 508 \text{ mm} + \frac{3,14}{2} (203,2 \text{ mm}) + \frac{1}{1,016 \text{ mm}} + (50,8 \text{ mm})^2$
 $= 508 \text{ mm} + 319,024 \text{ mm} + 2,54 \text{ mm}$
 $= 827,024 \text{ mm} + 2,54 \text{ mm}$
 $= 829,564 \text{ mm}$
 $= \frac{829,564 \text{ mm}}{25,4}$
 $= 37,66 \text{ inch}$

3) The amount of belt used (N)

$(D_p - d_p)/C = (127 - 76,2)/254$
 $= 0,2$

Correction factor (K_θ) = 0,99

Power capacity transmitter for a single belt (P_o) = 0.48 kW (with $n = 1400 \text{ rpm}$, pulley diameter = 76,2 mm)

$N = P_d / (P_o \cdot K_\theta)$
 $= (0,075) / (0,48 \cdot 0,99)$
 $= 0,139 \sim 1 \text{ unit}$

So the nominal number of the V-belt, Type A, Number 3, 1 unit, L = 73 inch.

c. The shaft dimension used

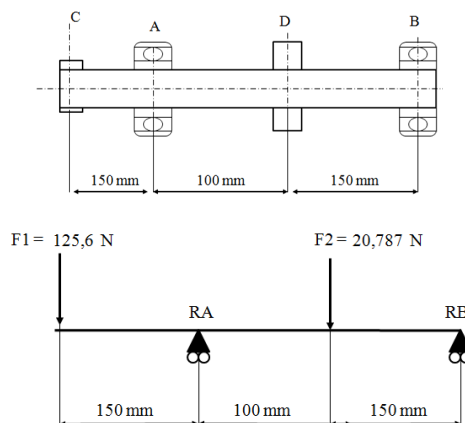

Picture 6. Free Body Diagram (FBD)

In which:

- τ_a = material shear stress = 28,33 (N/mm²)
- M_b = biggest entress moment = 18.840(Nmm)
- T = largest torque moment = 376 (N.mm)
- F_s = Security factor = 3

$$\sigma_b = \text{stretching power ST 37} = 340 \text{ (N/mm}^2\text{)}$$

$$\begin{aligned} d_1 &= [(5,1/\tau\alpha) \sqrt{(K_m \cdot M)^2 + (K_t \cdot T)^2}]^{\frac{1}{3}} \\ &= [(5,1/28,33) \sqrt{(1,5 \times 18.840)^2 + (3 \times 376)^2}]^{\frac{1}{3}} \\ &= [(5,1/28,33) \sqrt{(28.260)^2 + (1.128)^2}]^{\frac{1}{3}} \\ &= [0,180 \sqrt{799.899.984}]^{\frac{1}{3}} \\ &= [0,180 \times 28.282]^{\frac{1}{3}} \\ &= 17 \text{ mm} \end{aligned}$$

From the calculation above, it is obtained the result of the diameter of the shaft with the size of Ø17 mm. Due to the size of the cutting blade is Ø65 mm and diameter of bearings in the market is Ø75 mm, the size of the shaft used is Ø75 mm. To find the diameter of hollow shaft then it is used formula with the equation as follows:

$$\begin{aligned} \sigma_b &= \frac{M_b}{W_b} \\ \sigma_b &= \frac{M_b}{\frac{1}{64} (d_1^4 - d_2^4)} \\ d_2 &= \sqrt[4]{(d_1)^4 - \frac{64 \times M_b}{\sigma_b}} \\ d_2 &= \sqrt[4]{(75 \text{ mm})^4 - \frac{64 \times 18.840 \text{ N.mm}}{340 \text{ N/mm}}} \\ d_2 &= \sqrt[4]{31.640.625 \text{ mm} - \frac{1.205.760 \text{ N.mm}}{340 \text{ N/mm}}} \\ d_2 &= \sqrt[4]{31.640.625 \text{ mm} - 3.546} \\ d_2 &= \sqrt[4]{31.637.079 \text{ mm}} \\ d_2 &= 72,9 \text{ mm} \end{aligned}$$

From the calculation above, it has been obtained the size of the inner diameter of the perforated hollow with the size of Ø72.9 mm. But that size is considered less secure. Therefore, the inner diameter of the hollow shaft used is Ø65 mm.

The manufacturing process includes the production process, the assembly process, and the final process (finishing). The production process is the process of making from raw material to finished product, so it involves many machines such as cutting machines, lathes, drilling machines, grinding machines, and measuring equipment. The assembly process is a process of merging the finished product / component into one unified tool or machine. Equipment used is usually welding equipment. The final process (finishing) is the final work in every tool or machine making by painting the tool or machine as desired.



Picture 7. Painting process

Here is the form of the finished plastic cup ring cutting machine which is shown in picture 8. [5]

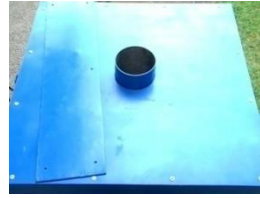

Picture 8. The design result

This plastic cup ring cutting machine is designed with two cutting blades. Where a vertical cutting blade has a thickness of 3 mm and a vertical blade can also be removed and sharpened so that the tip of the blade remains sharp to cut the plastic. Then the second blade is mounted and welded on the iron pipe, the iron pipe will rotate clockwise and will cut horizontally. The drive of this machine uses an electric motor which is connected using a V-belt. The height of this plastic cup cutting machine 90cm, 50cm for the width and 50cm for the length to ease the process whenever the plastic cup rings are cut because the cutting process is done in a standing position and is pressed manually using human power.

The testing process is done in 2 (two) stages, the first stage is to observe directly the supporting components according to their respective functions. After all the components are observed, it works properly. The second stage is testing the performance of machines against plastic cups. Test method is done as much as 10 times with 20 cups of plastic every one minute. The testing process includes the ability of the machine to cut the plastic cup rings. From the test results it is obtained cutting results using a plastic cups ring cutting machine, as shown below:



Picture 9. The result of plastic cup rings cutting

Here is the testing result:

Table 1. Comparison of the Test Result

No	Cutting		Time
	Manually	Using machine	
1	3 cups	12 cups	1 minute
2	4 cups	14 cups	
3	5 cups	17 cups	
4	4 cups	13 cups	
5	5 cups	16 cups	
6	3 cups	14 cups	
7	4 cups	13 cups	
8	3 cups	12 cups	
9	4 cups	14 cups	
10	5 cups	15 cups	
Average	5 cups	14 ups	

3.2 Discussion

The difference of the cutting result manually or by using machine can be clearly seen, since human physical ability which cannot be used continually, requires time-lapse, and prudential factor for safety in work.

The operation of either manual or machine-used cutting lasts for 5 hours for one day. If it is linked to the average time (table 1), the amount of the plastic cups without rings is as follows:

a. Manual way

Five plastic cups are cut for 1 minute, it means that one cup is cut for 0.2 minute, so in five hours the cups which have been cut are $(5 \times 60) / 0.2 = 1500$ plastic cups.

b. Cutting machine

14 plastic cups are cut for 1 minute. It means that one cup is cut for 0.07 minute, so in 5 hours the plastic cups cut are $(5 \times 60) / 0,07 = 4285,7 \sim 4286$ plastic cups.

The calculation results show an increase in the production of plastic cups that are cut with the cutting machine. Percentage increases in manual cutting compared with cutting by using machine for $(4286 - 1500) / 1500 \times 100\% \approx 186\%$. Thus the productivity of plastic cups has increased with the availability of plastic cups that can be recycled as much as 2786 cups.

4. CONCLUSION AND SUGGESTION

4.1 Conclusion

Based on the test result and the discussion, it can be concluded that:

- The machine can cut the cups faster than the manual way, so it can accelerate the recycling process of the polypropylene plastic.
- The collectors can accelerate the process of separating these types of plastic cups and the resulting pieces that are evenly distributed.

4.2 Suggestion

- In the process of cutting the plastic cup rings by using the machine, it is expected to still pay attention to the security.
- To set and sharpen the cutting blade so that at the operation time, it can be gotten maximum result.
- In pressing the plastic cup, the cup must be in perpendicular position to get a uniform cut.

REFERENCES

- [1].Rosnani Ginting. 2010. *Perancangan Produk*. Yogyakarta: Graha Ilmu.
- [2].Sato Takeshi. G, Sugiharto. N. H. 1996.*Menggambar Mesin Menurut Standar ISO*, Jakarta: Pradnya Paramita.
- [3]. Sularso dan Kiyukatsu Suga. 2004. *Dasar Perencanaan Dan Pemilihan Elemen Mesin*, Jakarta: PT. Pradnya Paramita
- [4]. M. Zaenuddin. 1998. *Degradation studies of activated polyethylene in polyethelene starch polyblend*, Bandung: ITB.
- [5]. Ginting Umumtha dan Sibarani S.M, 1995,*Manajemen Produksi*, Bandung: Pusat Pengembangan Pendidikan Politeknik